

## **Influence Of Work-Life Programs On Employee Engagement In Select It Companies**

**Sreya. B<sup>1</sup>, Dr. Lakshmana Rao Ayyagari<sup>2</sup>**

<sup>1</sup>Research Scholar, Dept. Of Commerce, SRM University - AP, Andhra Pradesh, India.

<sup>2</sup>Asst. Professor, Dept. Of Commerce, SRM University - AP, Andhra Pradesh, India.

---

### **Abstract**

The purpose of this study extends the possibility of employee engagement programs in various work-life programs. This purpose will allow the industries in improving the employee turnover ratio. The effect, quality, and refereeing role of work-life programs on employee engagement, self-motivation, and satisfaction level, are also stated in this study. The sample size of this study is 569, these samples were randomly collected from the employees of select IT companies from Kochi Techno Park. For arithmetical accuracy and the presence of missing values, only 550 samples were used for the analysis. Parametric tests were used to evaluate the collected samples. Further theories, concepts, and reviews are collected via existing literature reviews. The association among the constructs is examined using SEM and also measured the mediating role of WLP between the variables. The refereeing role of employee engagement is very much clear in work-life programs. Supportive work-life programs are implemented in select IT companies. The need and solution to such problems are described in this research. The current study offers a wide range of future agendas in factors influencing work-life and employee engagement in a similar industry. The study's main findings are associated with the mediation of WLP between the variables. All the variables are having good correlations. The present study expands the scope for further research gaps. The current research gap is analyzed and bridged in this research work. The current solution of context will help in categorizing the enhancement of programs in terms of quality work-life, satisfaction, and employee engagement in any organization. The validity and reliability of the current study have been tested by the researcher while conducting the research. From the manuscript, future agendas in factors influencing work-life and employee engagement in a similar industry can be identified.

**Keywords:** Employee engagement, Job resources, learning culture, cultural diversity, work-life programs, Management of technology, Job design, roles, and tasks.

### **1. INTRODUCTION**

Work-family balance is at the center of issues fundamental to human asset advancement (HRD). Grzywacz and Carlson (2008) give proof such that, certainly or expressly, work-family balance is at the center of HRD's significant capacities and that it very well might be a strong influence point for advancing individual and hierarchical viability. A balance between fun and

serious activities (WLB) has been an issue of worry throughout the previous few decades. The current setting of globalization and the changing idea of work has driven this theme. The current work situation is set apart by extreme strain, consistent cut-off times, evolving socioeconomics, high speed of progress, expanded utilization of innovation, and the virtual work environment. Compared with this, the increment in normal pay and ascend in expectations for everyday comforts have people taking a stab at a better work environment, further developing family and individual life. Today is when workers need everything. It isn't limited to one area of work or life yet rather a rich union of the two. "Ages X and Y are keeping the tension on organizations to devise adaptable, inventive choices that give high-performing representatives more decision and control in dealing with the contending requests of work and family" (Klun 2008). WLB analogy is a social development situated inside a specific timeframe and starting in the western setting. Research in this area arose when the number of ladies entering the work market developed and brought about attention to working moms and double worker families. Likewise, the pressure and burnout related to working environment changes during the 1980s and 1990s reflected a discussion around the "work-family struggle" (Lewis, Gambles, and Rapaport 2007). A shift from "work family" and "family cordial" approaches with their certain emphasis on ladies, particularly moms, to "work-life", the forerunner of the later WLB talk started during the 1990s (Lewis et al 2007). By and by, a large part of the examination in this space centers around work and family. Different terms that are utilized to allude to this area incorporate work-family balance, work-family struggle, work-family coordination, and family cordial strategies. These terms make the idea prohibitive by their very spotlight on just ladies with families. Zero in on single people and those without caring liabilities (of youngsters or seniors) however present is incredibly restricted. Ransome (2007) presented what he called "complete liability trouble" which incorporates "sporting work". This recognizes that people need to communicate and fulfill their requirements for delight and recreation. Yet, the other point of view is that in external formal, paid business, there is neglected work, such as mindful obligations, cooking, cleaning, and so on and relaxation time is only a dream (Collins 2007). A balance between serious and fun activities is a lot more extensive idea requiring consideration not simply too wedded, with youngsters' couples or working moms but to working people at large, whether or not they are hitched, and whether or not they have family commitments. Heightening of work and innovation that obscures the limit among work and the remainder of life gives difficulties to every last one. Serious and client pressure has constrained organizations to support and rebuild, and as a result, fewer individuals need to accomplish more work (Poelmans, Kalliath, and Brough 2008). WLB ought not to be believed to mean harmony among work and family however that among work and the remainder of life. By relating WLB to the vocation stage, Sturges (2008) incorporates more youthful experts without family obligations into the area. It is a widely inclusive issue that is relevant for anybody requiring individual space. Seen thusly, this idea has importance to a bigger crowd. The tight conceptualization of WLB depicts the person as being conflicted between the requests of work and family. It loses contact with the actual embodiment of being human. Human existence isn't just with regards to needing yet in addition to the decision and by recognizing that people need to seek after their cravings and fulfill their requirements, a notional person of WLB is presented which has its natural utility. Guest (2002) has tried to

break the tight limits of the WLB idea and has recognized the pertinence of WLB for all people by outlining the areas of work, and as he calls it, "the remainder of life". Subsequently, it doesn't remain confined to just working people with families. The driving force for research on WLB has been animated by the appearance of Generation X, a partner of laborers who give a more noteworthy need to look for a balance between work and the remainder of life (Guest 2002).

### **1.1 CONCEPT AND TYPES OF EMPLOYEE ENGAGEMENT**

In the ISO 9001–2015 norm, the principle "Representative commitment" is defined as infers the rise of inspiration, dynamic investment, and association of laborers in all creative processes, which ought to well affect the development of work effectiveness. Individuals start to work viably provided that they are energetic about work. To accomplish this, it is important to make conditions for the most extreme interest of representatives in their work. It is accepted that worker fulfillment with his work brings about his faithfulness to the business, dependability structures commitment, which, thusly, permits work on the nature of items (Stevenson, 2019). It merits explaining that the ideas of "representative inspiration" and "worker commitment" ought not to be confounded. Understandings of the idea of commitment in different examinations show an absence of logical agreement in deciding the limits of representative commitment. Many terms that appear to be comparative to the significance of the term worker commitment, make it hard to see the peculiarity as a free development. The ideas of inspiration and commitment vary in that inspiration propels you to achieve specific assignments while commitment isn't just with regards to undertakings, it is about comprehension (inundation) just as execution (energy), which advances elite execution (Bakker, 2011). With research demonstrating that representative commitment lessens word-related weariness, interest in commitment has developed considerably quicker (Shuck and so on, 2013). As per the perspective of a few researchers, worker commitment is essentially an individual's inclination to take part specifically in a work movement, which comprises three parts: information, interest, and execution (Meiyani and so forth, 2019). Information on the work that the worker does, in a mix with the craving to get patterns, command mitment (Guest, 2014; Aninkan and so on, 2014). By D. Visitor the effectiveness of the association and the development of financial pointers depends on the hierarchical commitment, or the representative's prosperity workers' commitment themselves (Guest, 2014).

Can be accepted, the association's aspiration to build proficiency by expanding representative commitment won't be completely effective on the off chance that all activities will be limited to outlining worker commitment. On one side the adequacy of commitment employees is higher than non-engagement representatives and this is in light of a legitimate concern for the association, on the opposite side the best advantage of the drew-in worker is their proficient accomplishments. They survey the association by working conditions, compensation, and social administration. They will change the association assuming these conditions are not met. In Table 1 can see contrasts among employees and authoritative commitment: the association is in the runner up, association esteems and association improvement are not significant, don't effectively address the association's life, because such representatives turn out just for themselves.

## **1.2 LEVELS OF EXPRESSION OF EMPLOYEE ENGAGEMENT**

As per Bakker et al. (2012), it is vital to look not just at factors at various degrees of representative commitment, yet in addition at the component of their activity. Individual factors that structure the representatives' commitment incorporate the individual qualities of the worker. Kahn distinguishes such representative qualities, which are important for worker commitment:

- freedom to demonstrate enthusiasm and not to be anxious about the possibility that it will harm your picture, vocation, or status;
- capacity to utilize your physical, enthusiastic, and mental assets, which are perceived as an interest in the accomplishment of an association;
- understanding that mental and actual exertion will be valued.

Gallup fostered various leveled models specifically HRM Key Performance Indicators (KPI) embraced from Herzberg's, (Meiyani and so on, 2019) and utilized for measuring worker commitment in many organizations incorporating dispersion organization. In the Gallup progressive system, there are four principal aspects and 12 fundamental markers to accomplish commitment pecking order in the association. For example, fundamental necessities the executives backing, cooperation and, the development comprises of; progress over the most recent a half year, freedoms to learn and develop.

## **1.3 EMPLOYEE ENGAGEMENT AND PRACTICES OF HRM**

Empowering representative commitment at the individual and hierarchical level is a significant pretends department of human resources on the board. The present exact examination permitted the logical bits of knowledge to apply by and by. Current exploration in human assets the executives show that exceptionally gifted experts all the more frequently are searching for occupations where are holding up difficulties is giving vocation development opportunity and the conditions for becoming locked in. As such, searching for a task they progressively are showing an inward inspiration and need for development and the likely requirement for commitment. In this way, to draw in the potential drew in employees, the course of employee's choice and requirement should depend on determination strategies, which will assist with picking probably going to be locked in the testing, organized meeting, master assessment, proposals (Guest, 2014). For instance, A. Bread cook found, that individual characteristics like genuineness and extraversion, decidedly impact the penchant to connect with others (Baker, 2014). These characteristics, as inborn inspiration, arise during a persuasive meeting. It is vital to specify that such a work serious interaction as drawing in connected representatives loses its significance, assuming their upkeep isn't adequately ensured. Representatives, who will more often than not get ready for marriage, keeping in the association helps hierarchical socialization, which guarantees the coordination of workers in the social arrangement of the association. This reconciliation is slow osmosis of the components of the association culture: formal and casual standards of conduct in the association, the qualities, convictions, and goals of the association. In this manner, the HR administrators can draw in workers with solid characteristic inspiration, who have a high potential for commitment. In-kind, to uncover their

potential and to keep up with in association, the administrators must guarantee and keep an appropriate authoritative culture. Another significant viewpoint, which adds to worker maintenance in association and which is an instrument for expanding commitment, is an outside inspiration arrangement of staff. Such a framework incorporates material and non-material instruments of excitement for inspiration. It depends on the idea of a reasonable award (Rubel et al., 2018). Additionally need to refer to such acts of the executive's human asset as group building. This permits the expansion of the commitment impact in the association. Acknowledgment of different strategies for gathering and collaboration guarantees the change of individual commitment into full group commitment which firmly impacts the upper hand.

## **2. Employee Engagement: Key Ingredients**

Employee Engagement Defined" shows instances of commitment definitions utilized by different companies and consultancies. Meanings of worker commitment change significantly across associations. Numerous chiefs can't help thinking about how such a slippery idea can be evaluated. The term incorporates a few elements for which analysts have created estimation procedures. These fixings incorporate the degree to which representatives completely involve themselves in their work, just as the strength of their obligation to the business and job. Luckily, there is a lot of exploration on these components of commitment—work that has profound roots in individual and gathering brain science.

### **2.1 Occupying the Job**

Analyst William Kahn drew on investigations of work roles and hierarchical examine the degrees to which individuals "possess" work jobs. He utilized the terms "individual commitment" and "individual withdrawal" to address two closures of a continuum. At the "individual commitment" end, people completely possess themselves, mentally and inwardly—in their work job. At the "individual withdrawal" end, they uncouple themselves and pull out of the job. How do individuals become occupied with their work exercises? For what reason do they become more occupied with certain exercises than others? Researchers have proposed replies to these inquiries dependent on their investigations of the brain research of responsibility.

### **2.2 Committing to the Work and the Company**

A few specialists characterize responsibility as both an eagerness to endure in a strategy also hesitance to change plans, regularly attributable to an awareness of certain expectations to keep with it. Individuals are at the same time focused on numerous substances, for example, financial, instructive, familial, political, and strict institutions. They additionally invest in explicit people, including their companions, youngsters, guardians, and kind, just as to their managers, colleagues, chiefs, and clients. Responsibility shows itself in particular conduct. For instance, individuals dedicate time what's more energy to satisfy their hands-on liabilities just as their family, individual, local area, and profound commitments. Responsibility likewise has a passionate part: Individuals normally experience and express good inclinations toward an element or individual to whom they have committed. Finally, responsibility has an objective component: The vast majority deliberately choose to take responsibility, then, at that point,

they insightfully plan furthermore complete the activities needed to satisfy them. Since responsibilities require a venture of time just as mental and enthusiastic energy, the vast majority make them with the assumption for the response. That is, individuals, accept that in return for their responsibility, they will get something of significant worth return like blessings, warmth, gifts, consideration, merchandise, cash, and property. In the universe of work, representatives and managers have generally settled on an unsaid understanding: In trade for laborers' responsibility, associations would give types of significant worth to representatives, like secure positions and reasonable remuneration. Correspondence influences the power of responsibility. At the point when an element or individual to whom somebody has made responsibility neglect to come through with the normal trade, the responsibility disintegrates.

### 2.3 The Link Between Employer Practices and Employee Engagement

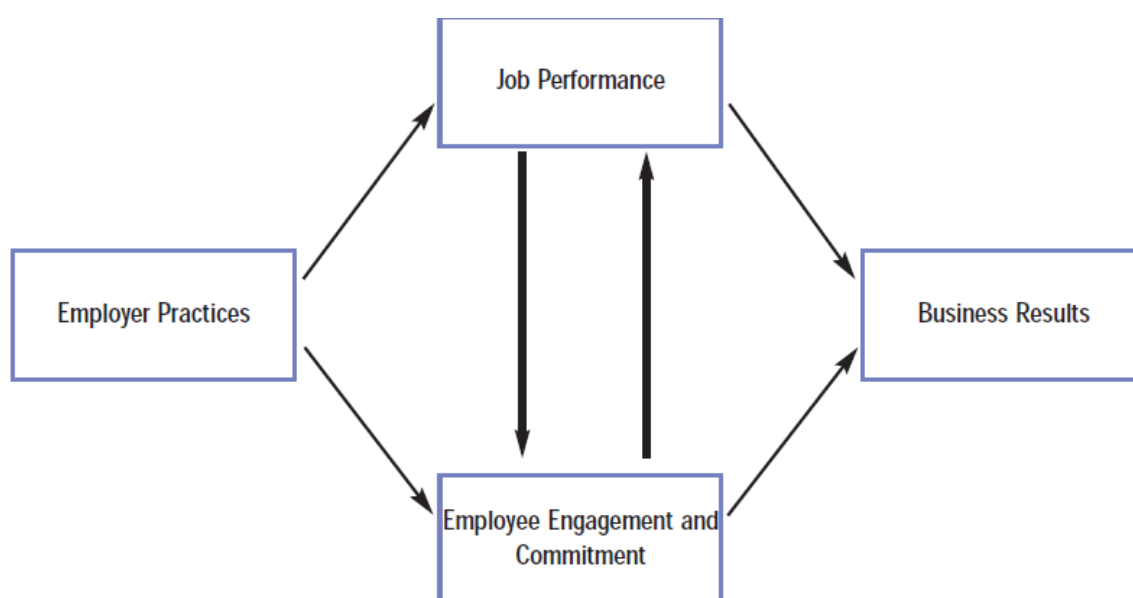

How does a connection with the labor force create important business results for an association? The cycle begins with management practices, for example, work and undertaking plan, enrolment, choice, preparing, remuneration, execution of the executives, and vocation advancement. Such practices influence workers' level of commitment just as occupation execution. Execution and commitment then, at that point, connect to create business results. To draw in laborers just as to profit from that commitment, your association must put resources into its human asset rehearses. In any case, very much like different ventures, you want to consider the likely return that is, to commit assets to the HR rehearses you trust will produce "the greatest bang" for the venture "buck." leaders should gauge how much commitment and responsibility your organization needs—and at what cost. Underneath, we audit manager rehearses that influence representative commitment and responsibility and analyze ways to control these "switches" to impact commitment or responsibility or both.

### 2.4 OBJECTIVES

- Identifying the mediating role of WLP between satisfaction level and employee engagement.
- To find the influence of employee engagement on job performance.
- To observe the age, have any influence on key factors like satisfaction level, WLP, and employee engagement.
- Identify the relationship between satisfaction level, WLP, and employee engagement.

### 3. CONCEPTUAL MODEL



The conceptual model is the simple diagram that shows the relationship between the main variables of the study, namely Satisfaction of the employees, Work-life programs, and employee engagement. This model will be tested for further analysis.

#### 3.1 Constructs of the variables of the conceptual models

##### 3.1.1 Satisfaction of employees

- Appreciation for your work.
- Good relationships with colleagues.
- Good work-life balance.
- Good relationships with superiors.
- Company's financial stability.

##### 3.1.2 Work-life programs

- Attitude
- Environment
- Opportunities
- Nature of Job
- Stress Level
- Career Prospects

##### 3.1.3 Employee engagement

- Adopt a Learning Culture
- Cultural Diversity
- Transparency and Honesty
- Autonomy
- Inspiration

### 4. Reliability

Reliability means the ability of the measuring instrument to give accurate and consistent results. It measures the relative absence of errors in a measuring instrument since the less the error the more stable and more accurate the data is (De Von et al., 2007). Internal consistency is one of the methods of measuring scale reliability by determining the generality of a set of items measuring a particular construct and here the researcher used Cronbach's alpha to measure the internal consistency in measuring the scale test. If Cronbach's alpha is more than 0.7, the scale is reliable.

**Table 1: Assessment of Construct Reliability for satisfaction level**

<b>Construct</b>	<b>Cronbach's alpha (<math>\alpha</math>)</b>
Appreciation for your work.	0.806
Good relationships with colleagues.	0.841
Good work-life balance.	0.826
Good relationships with superiors.	0.765
Company's financial stability	0.829

It is identified from the table that Cronbach's alpha for all the satisfaction levels is higher than 0.7. So, all the constructs are reliable and fit for further analysis.

**Table 2: Assessment of Construct Reliability for WLP**

<b>Construct</b>	<b>Cronbach's alpha (<math>\alpha</math>)</b>
Attitude	0.706
Environment	0.834
Opportunities	0.825
Nature of Job	0.745
Stress Level	0.812
Career Prospects	0.743

It is identified from the table that Cronbach's alpha for all the WLP is higher than 0.7. So, all the constructs are reliable and fit for further analysis.



**Table 3: Assessment of Construct Reliability for employee engagement**

Construct	Cronbach's alpha ( $\alpha$ )
Adopt a Learning Culture	0.806
Cultural Diversity	0.834
Transparency and Honesty	0.815
Autonomy	0.765
Inspiration	0.845
Adopt a Learning Culture	0.729

It is identified from the table that Cronbach's alpha for all the employee engagement is higher than 0.7. So, all the constructs are reliable and fit for further analysis. From the above tables, it is observed that all the constructs of the main variable of the study are found to be reliable, thus using these constructs the variables are fit and can be used for further analysis.

**Table 4: Validity of Cronbach alpha of different variables**

Sl no	Name of the variable	Number of items	Final items	Mean	SD	Cronbach alpha
1	Satisfaction level	27	24	3.34	0.45	0.95
2	WLP	19	17	4.1	0.85	0.89
3	Employee engagement	18	15	3.8	0.37	0.91

**Table 5: KMO and Variances of Different variables**

Construct	KMO	Variances
Satisfaction level	0.923	62.324%
WLP	0.892	65.562%
Employee engagement	0.934	70.772%
Self-motivation	0.881	71.324%

**Table 6: Data Structure of Sample Population**

Company	Employees	QE given	Received
Kochi info park	48,000	569	550

Reliability and validity are tested and it is found to be fit, Cronbach alpha values are above the standard limit and the KMO values are also good, each item explains a good level of variances and the total variances explained is 85%. The factor analysis shows four factors were extracted.

## 5. TEST FOR MEDIATION

### 5.1 H0 there is no mediation by WLP

H01 there is no impact on WLP by appreciation.

H02 there is no impact on WLP by a relationship with colleagues.

H03 there is no impact on WLP by Work-life balance.

H04 there is no impact on WLP by a relationship with superiors.

H05 there is no impact on WLP by financial stability.

H06 WLP has no impact on learning culture.

H07 WLP has no impact on cultural diversity.

H08 WLP has no impact on transparency.

H09 WLP has no impact on autonomy.

H010 WLP has no impact on inspiration.

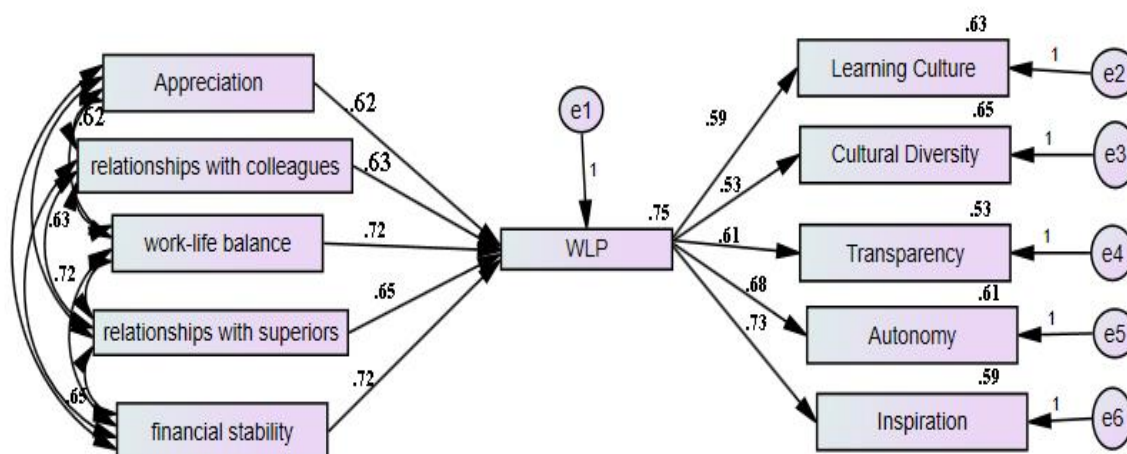

**Table 7: Goodness of fit of the mediation work-life programs**

Indices	$\chi^2/df$	P	GFI	AGFI	NFI	TLI	CFI	RMSEA	RMR
Model Value	1.231	.308	.998	.994	.996	.996	.972	.018	.024

The chi-square value is 1.21, P-value is .308, GIF is .988, AGIF is .944, NFI is .996, TLI is .996 CFI is .972, CIF is .972 RMSEA is 0.18 and RMR is .024 which indicate the model is fit. It is found that the variances explained by the satisfaction level, work-life programs, and employee engagement is .75 percent. The mediating effect of WLP on culture is .59 percent, the mediating effect of WLP on diversity is .65 percent, the mediating effect of WLP on transparency is .53 percent, and the mediating effect of WLP on autonomy is .61 percent, The mediating effect of WLP on inspiration is .59percentage. Appreciation is having a 62-percentage impact on WLP. Relationship with college is having a 63 percent impact on WLP. Work-life balance is having a 72 percent impact on WLP. Relationship with the supervisor is having a 65 percent impact on WLP. Financial stability is having a 72 percent impact on WLP. WLP is having a 59 percent impact on learning culture. WLP is having a 53 percent impact on cultural diversity. WLP is having a 61 percent impact on transparency. WLP is having a 68 percent impact on autonomy. WLP is having a 73 percent impact on inspiration.

## 5.2 MULTIPLE REGRESSION ANOVA

H011 employee engagement is not influenced job performance

**Table 8: ANOVA of Employee engagement and job performance**

Model	Sum of squares	df	MS	F	Sig.
Regression	29.82	65	4.192	5252	.000 <sup>b</sup>
Residual	.219	67	.001		
Total	30.039	132			

**Table 9: Model summary**

Model	R	R Square	Adjusted R Square	Std. Error of the Estimate	Change Statistics					Durbin-Watson
					R Square Change	F Change	df1	df2	Sig. F Change	
	.863 <sup>a</sup>	.744	.731	.72569	.779	13.245	547	548	.000	2.279

Employee engagement is the main factor that is leading to job performance, more employees are properly engaged with a view of minimal effort and maximum output. The regression results provided above show that the influence of employee engagement is having a greater

impact on job performance ( $R=.73$ ). ANOVA result is also providing support to this with a (.000 sig) level.

### 5.3 Difference of opinion between the age of the respondents with responses to satisfaction, WLP, and Employee Engagement - ANOVA

H012 there is a significant difference between the age of the respondent and job satisfaction.

H013 there is a significant difference between the age of the respondent and the work-life program.

H014 there is a significant difference between the age of the respondent and employee engagement.

**Table 10: Anova of the age of respondents and Job satisfaction**

Variables	Labels			
		Df	F	Sig.
Job satisfaction	BG	3	.919	.82
	WG	54		
	Tot al	55 0		
Work-life program	BG	3	.167	.410
	WG	54		
	Tot al	55 0		
Employee engagement	BG	3	.039	.340
	WG	54		
	Tot al	55 0		

Results of the ANOVA show that the age of the respondents and job satisfaction is having no significant difference (sig 0.82), the age of the respondent and work-life programs are not significantly different (sig 0.41), age of the respondent and employee engagement are not significantly different (sig 0.34).

### 5.4 CORRELATIONS

H015 There is no relationship between job satisfaction and WLP

H016 There is no relationship between job satisfaction and employee engagement

H017 There is no relationship between WLP and employee engagement

**Table 11: Relation among key variables**

	Job satisfaction	Work-life program	Employee engagement
Job satisfaction	1.00	.823	.721
Work-life program	.823	1.00	.788
Employee engagement	.721	.788	1.00

Significance level 0.001

The relation between the key variables is examined from the above table Job satisfaction is having (.832) relationship with WLP, Job satisfaction is having (.721) relationship with Employee engagement, and WLP is having a (.788) relation with employee engagement. So that the relationship between job satisfaction, WLP, and employee engagement is very high and positive.

## 6. CONCLUSION

The present study tries to prove the importance of the work-life balance in a firm by the way the employees can increase their satisfaction level and their commitment to the firm. It also studies the various aspects of employee engagement and its influence on the satisfaction level. Findings revealed that the mediation role of WLP is greater between the satisfaction level and employee engagement. In any case, this study has a few impediments. All actions were gathered from self-revealed polls inside a solitary area, and the outcomes acquired in this examination can be additionally approved through comparative investigations in different areas and areas. The review estimated worker WLP and different factors of interest at a guaranteed mark of time, which might be affirmed through a longitudinal report. The example has more male members (72.9 percent) than females as regulation authorization work (populace) is a male-overwhelmed calling worldwide and an alert ought to be taken while alluding to the result for different callings with orientation variety. Concentrations on interceding jobs seen WLP did especially among police officers across the world have been scant, and the current exploration was picked to be a driving force for future research in work-life writing. The current examination can be a trailblazer for future exploration toward understanding the interceding relationship of seen WLP and the directing job of fulfillment with hierarchical WLP methodologies between different other hierarchical variables and results as the concentration here is just between work over-burden and professional responsibility.

## References

- Brooks, B.A., and Anderson, M.A. (2005), "Defining quality of nursing work life", *Nursing Economics*, Vol. 23 No. 6, pp. 319–326.
- Curry, J. P., Wakefield, D. S., Price, J. L., Mueller, C. W., and McCloskey, J. C. (1985), "Determinants of turnover among nursing department employees", *Research in Nursing and Health*, Vol. 8 No. 4, pp. 397-411.
- Che Rose, R., and, L. S., Uli, J., and Idris, K. (2006), "Quality of work life: Implications of career dimensions", *Journal of Social Sciences*, Vol. 2 No.2, pp. 61-67.

- Chelte, A. F. (1983), "Organizational commitment, job satisfaction and quality of work-life", U.M.I. Dissertation information service.
- Cunningham, J. B., and Eberle, T. (1990), "A guide to job enrichment and redesign", *Personnel*, Vol. 67 No. 2, pp. 56-61.
- Delamotte, Y., and Walker, K. F. (1976), "Humanization of Work and the Quality of Working Life— Trends and Issues", *International Journal of Sociology*, Vol. 6 No. 1, pp. 8-40.
- Hackman, J. R., and Oldham, G. R. (1980), "Work redesign, Redesigns. MA: Addison", Wesley.
- Hian, C. C., and Einstein, W. O. (1990), "Quality of work-life (QWL): What can Unions Do?", *SAM Advanced Management Journal*, Vol. 55 No. 2, pp. 17.
- Mirvis, P. H., and Lawler III, E. E. (1984), "Accounting for the quality of work-life", *Journal of Organizational Behavior*, Vol 5 No. 3, pp. 197-212.
- Robins, S.P. and Judge, T.A., (2001), "Organizational behavior", New Jersey, 9th prentice-Hall Inc.
- Scully, J., Kirkpatrick A., Locke, E., (1995), "Locus of Knowledge as a Determination of the Effects of Participation on Performance, Affect, and Perceptions", *Organizational Behaviour Human Decision-Making Process*, Vol 61, pp. 276-288
- Sirgy, M.J., Efraty, D., Siegel, P., and Lee, D.J. (2001), "A new measure of the quality of work-life (QWL) is based on need satisfaction and spill over theories", *Social Indicators Research*, Vol 55 No. 3, pp.241-302.
- Skrovan, D. J. (1983), "Quality of work-life perspectives for business and the public sector", London: Addison-Wesley.
- Winter, R., Taylor, T., and Sarros, J. (2000), "Trouble at the mill: quality of academic work-life issues within a comprehensive Australian university", *Studies in Higher Education*, Vol 25, pp. 279-94.
- Andrew, O.C., Sofian, S., (2012), "Individual factors and work outcomes of employee engagement", *Procedia— Social and Behavioural Sciences*, Vol 40, Pp. 498-508.
- Bakker, A.B. (2011), "An evidence-based model of work engagement", *Current Directions in Psychological Science*, Vol 20 No. 4, Pp. 265-269.
- Bakker, A. B., and Demerouti, E. (2014), "Job demands-resources theory. Wellbeing", *A complete reference guide*, pp. 1-28.
- Pereira, M. M., Ferreira, M. C., and Valentini, F. (2019), "Occupational satisfaction of physicians: The impact of demands and resources", *Paidéia (Ribeirão Preto)*, Vol. 29.
- Bakker, A.B., Tims, M., Derks, D., 2012, "Proactive personality and job performance: The role of job crafting and work engagement", *Human Relations*, Vol. 65 No. 10, Pp. 1359-1378.
- Businessweek, B. (2010), "The role of employee engagement in the return to growth", *Corporate Executive Board*, Vol 10.
- Barney, J. (1991), "Firm resources and sustained competitive advantage", *Journal of Management*, Vol 17, pp 99–120.

- Barney, J. (1995), "Looking inside for competitive advantage", *Academy of Management Executive*, Vol 9 No. 4, pp. 49–61.
- Baumruk, R., Gorman, Jr., B., and Gorman, R.E. (2006), "Why managers are crucial to increasing engagement: Identifying steps managers can take to engage their workforce", *Strategic HR Review*, Vol 5 No. 2, pp. 24-7.
- Chartered Institute of Personnel and Development (2006), "Working Life: Employee Attitudes and Engagement", London: CIPD.
- Gallup (2006), "Engaged employees inspire company innovation", *Gallup Management Journal*.
- Cheema, S., Akram, A., Javed, F., (2015), "Employee engagement and visionary leadership: impact on customer and employee satisfaction", *Journal of Business Studies Quarterly*, Vol 7 No 2, Pp. 139-148.
- Chen, P.Y., Cooper, C.L., (2014), "Wellbeing: A complete reference guide, Volume III, Work and Wellbeing. Part 3 Happy Workers and Happy Organizations" Peter Hosie, Nada ElRakhawy, Bret L. Simmons. New York, NY, Pp. 113-139.
- Crawford, E.R., Rich, B.L., Buckman, B., Bergeron, J., (2013), "The antecedents and drivers of employee engagement", *Employee engagement in theory and practice*, pp. 57-81.
- Demerouti, E. and Cropanzano R. (2010), "From thought to action: employee work engagement and job performance", *Work Engagement: A Handbook of Essential Theory and Research*, pp. 1447-163.
- Eskildsen J.K., Nussler M.L. (2000), "The managerial drivers of employee satisfaction and loyalty". *Total Quality Management*, Vol. 11 No. 4-6, pp. 581-588.
- Guest D. (2014), "Employee engagement: A skeptical analysis", *Journal of Organizational Effectiveness: People and Performance*, Vol. 1 No. 2, pp. 141-156.
- Hewitt A., (2019), "2019 Trends in Global Employee Engagement" [https://www.kincentric.com/-/media/kincentric/pdfs/kincentric\\_2019\\_trends\\_global\\_employee\\_engagement.pdf](https://www.kincentric.com/-/media/kincentric/pdfs/kincentric_2019_trends_global_employee_engagement.pdf)
- Humphrey S.E., Jennifer D.N., Frederick P.M. (2007), "Integrating motivational, social, and contextual work design features a meta-analytic summary and theoretical extension of the work design literature", Vol. 25, pp. 1332-1356.
- Hackman J.R. (2002), "Leading Teams: Setting the Stage for Great Performances", Boston, MA: Harvard Business School Books.
- Hackman J.R. and Oldham G.R. (1974), "Motivation through the design of work", *Organizational Behaviour and Human Performance*, Vol. 16 No. 2, pp. 250–79.
- Harter J.K., Schmidt F.L. and Hayes T.L. (2002), "Business-unit-level relationship between employee satisfaction, employee engagement, and business outcomes: a meta-analysis", *Journal of applied psychology*, Vol. 87 No. 2, pp. 268–79.
- Kahn W.A. (1990), "Psychological conditions of personal engagement and disengagement at work", *Academy of Management Journal*, Vol. 33 No. 4, pp. 629-724.

- Crawford E.R., Rich B.L., Buckman B., Bergeron J. (2013), "The antecedents and drivers of employee engagement", *Employee engagement in theory and practice*, pp. 57-81.
- Demerouti E., Cropanzano R. (2010), "From thought to action: employee work engagement and job performance".
- A. B. Bakker and M. P. Leiter (Eds.) (2010), "Work Engagement: A Handbook of Essential Theory and Research" New York: Psychology Press, pp. 1447-163.
- Dhanabhakya M. and Monish P. (2021), "Impact of Employee Grievance Identification Strategies on Job Performance with Special Reference to Info Park and Techno Park, Kerala". *Asian Journal of Managerial Science*, Vol. 10 No. 1, pp. 33-35.
- Eskildsen J.K., Nussler M.L. (2000), "The managerial drivers of employee satisfaction and loyalty", *Total Quality Management*, Vol. 11 No. 4-6, pp. 581-588.
- Guest D. (2014), "Employee engagement: A skeptical analysis", *Journal of Organizational Effectiveness: People and Performance*, Vol. 1 No. 2, pp. 141-156.
- Humphrey S.E., Jennifer D.N., Frederick P.M. (2007), "Integrating motivational, social, and contextual work design features a meta-analytic summary and theoretical extension of the work design literature", Vol. 25, pp. 1332-1356.
- Joseph E., and Dhanabhakya M. M. (2022), "Role of Digitalization Post-Pandemic for Development of SMEs. In *Research Anthology on Business Continuity and Navigating Times of Crisis*", pp. 727-747.
- Kahn W.A., (1990), "Psychological conditions of personal engagement and disengagement at work", *Academy of Management Journal*, Vol. 33 No. 4, pp. 629-724.
- Monish P., and Dhanabhakya M. (2021), "Sustainability Strategies for Developing SMEs and Entrepreneurship", In *Handbook of Research on Sustaining SMEs and Entrepreneurial Innovation in the Post-COVID-19 Era*, pp. 527-547
- Schaufeli W.B. (2018), "Work engagement in Europe: Relations with the national economy, governance, and culture", *Organizational Dynamics*, Vol. 47, pp. 99-106.
- Shuck B., Rose K. (2013), "Reframing employee engagement within the context of meaning and purpose: Implications for HRD", *Advances in Developing Human Resources*, Vol. 15, pp. 341-355.
- Soni B.S., (2013), "Employee engagement - A key to organizational success in the 21st century", *Voice of Research*, Vol. 1 No. 4, pp. 51-55.
- Stevenson M., (2019), "Employee Engagement: Everything You Need to Know." <https://www.hrexchangenetwork.com/employee-engagement/articles/employee-engagement-everything-you-need-to-know>
- Saks A. M. (2006), "Antecedents and consequences of employee engagement", *Journal of Managerial Psychology*, Vol. 21 No. 7, pp. 600-19.
- Shirom A. (2003), "Job-related burnout: A review", in J.C. Quick and L.E. Tetrick (Eds.), *Handbook of Occupational Health Psychology* pp. 245-65
- Xanthopoulou D., Bakker A.B., Demerouti E., Schaufeli W.B. (2009), "Work engagement and financial returns: A diary study on the role of job and personal resources", Vol. 82 No. 1, pp. 183-200



- Hackman J.R. (2002), "Leading Teams: Setting the Stage for Great Performances, Boston", MA: Harvard business school Books.
- Humphrey S.E., Jennifer D.N., Frederick P.M., (2007), "Integrating motivational, social, and contextual work design features a meta-analytic summary and theoretical extension of the work design literature", Vol. 25, pp. 1332-1356.
- Hackman J.R. and Oldham G.R. (1974), "Motivation through the design of work", *Organizational Behaviour and Human Performance*, Vol. 16 No. 2, pp. 250–79.
- Harter J.K., Schmidt F.L., and Hayes T.L. (2002), "Business-unit-level relationship between employee satisfaction, employee engagement, and business outcomes: a meta-analysis", *Journal of applied psychology*, Vol. 87 No. 2, pp. 268–79.
- Kahn W.A. (1990), "Psychological conditions of personal engagement and disengagement at work", *Academy of Management Journal*, Vol. 33 No. 4, pp. 692–724.
- Ketter P. (2008), "What's the big deal about employee engagement?", *American Society for Training and development*, pp. 45–49.
- Luthans F., Peterson S.J., and Farmer R.T. (2002), "Employee engagement and manager self-efficacy", *Journal of Management Development*, Vol. 21 No. 5, pp. 376–87.
- Macey W.H. and Schneider B. (2008), "The meaning of employee engagement, *International and Organizational Psychology: Perspectives in Science and Practice*".
- Mowday R.T., Steers R.M., and Porter L.W. (1979), "The measurement of organizational commitment", *Journal of Vocational Behavior*, Vol. 14, pp. 224–47.
- Riketta M. (2002), "Attitudinal organizational commitment and job performance: A meta-analysis", *Journal of Organizational Behavior*, Vol. 23, pp. 257–66.
- Saks A. M. (2006), "Antecedents and consequences of employee engagement", *Journal of Managerial Psychology*, Vol. 21 No. 7, pp. 600–19.
- Shaw K. (2005), "Employee Engagement: How to Build a High-performance Workforce", Chicago, IL: Melcrum Publishing Limited.
- SHRM (2008), "White Paper: Employee Engagement and Organizational Performance: How do you know your employees are engaged?", [www.shrm.org/hrresources/whitepapers\\_published/CMS\\_012127.asp](http://www.shrm.org/hrresources/whitepapers_published/CMS_012127.asp).
- Ulrich D. and Brockbank W. (2005), "HR Value Proposition", Cambridge, MA: Harvard Business Press.
- Vance R. (2006a), "Employee Engagement and Commitment", Alexandria, VA: SHRM.
- Vance R.J. (2006b), "Employee engagement and commitment: A guide to understanding, measuring and increasing engagement in your organization", *Society for Human Resource Management*, pp. 1–45.
- Welbourne, T.M. (2007), "Employee engagement: Beyond the fad and into the executive suite", *Leader to Leader*, spring pp. 45–51
- Welbourne, Johnson D and Erez A. (1998), "The role-based performance scale: Validity analysis of a theory-based measure of performance", *Academy of Management Journal*, Vol. 41, No. 5, pp. 540–55.